



We Can Support All Your Equipment Need

The Customer And Product Supplied By Classification

The Customer Supplied by Classification

- Airport
- Product processing works
- Chemical works
- Dockyards & dokland
- Engineering works
- Metal manufacturing
- Petroleum Product
- Power Station
- Pulp and paper manufacturing work
- Textile works and dye works
- Waste recycling
- Oil refineries & Bulk storage of petroleum
- Etc



The Product Supplied by Classification

- Metal cutting
- Clamping
- Measurement
- Testing equipment
- Workshop equipment
- General tools
- Grinding
- Electric tools
- Welding machine and equipment
- Marine equipment
- Pressure vessel Equipment
- Painting , Foam , Invisipack
- Etc



Brand And Product Overview



Table Of Contents

- 1. Welding Solution**
Special / General Welding Electrode & Filler
- 2. Cutting Tools Solution**
Special / General Holder & Insert with Accesories
- 3. Part Solution**
Special / General Product Part

- 4. Product Support Welding Machine, Accesories And Part Solution**
- 5. Product Support General Solution**
- 6. Product Support System and Service Solution**

Special / General Welding Electrode & Filler

1

Solutions for Welding Alloys

Welding Consumables

FORGING & FOUNDRY FOOD INDUSTRY NUCLEAR AND THERMAL PLANTS, POWER INDUSTRY MINING INDUSTRY

SHIPBUILDING INDUSTRY AUTOMOBILE INDUSTRY CHEMICAL AND PETROCHEMICAL INDUSTRY M & R INDUSTRY

LOW ALLOY STEELS

- CrMo creep resisting
- MnMo low alloy steels
- High toughness Ni bearing low alloy steels
- High strength low alloy steels

High temperature alloys

- High carbon 300 series stainless steels
- High temperature 309 and 310 stainless steels
- High carbon austenitic alloys including 330, 800, HP40

STAINLESS STEELS

- Martensitic stainless steels
- Austenitic stainless steels
- 309L and 309Mo stainless steels
- Superaustenitic, lean duplex, duplex and superduplex stainless steels

Nickel base alloys

- 182 type alloys
- 625 type alloys
- Alloy C types
- Specialist nickel base alloys
- Nickel based non-ferrous alloys



Filler rod for root pass ⁽¹⁾	VDM			
	TG-X308L (2.2mmØ)	TG-X316L (2.2mmØ)	TG-X309L (2.2mmØ)	TG-X347 (2.2mmØ)

AVESTA 253 MA

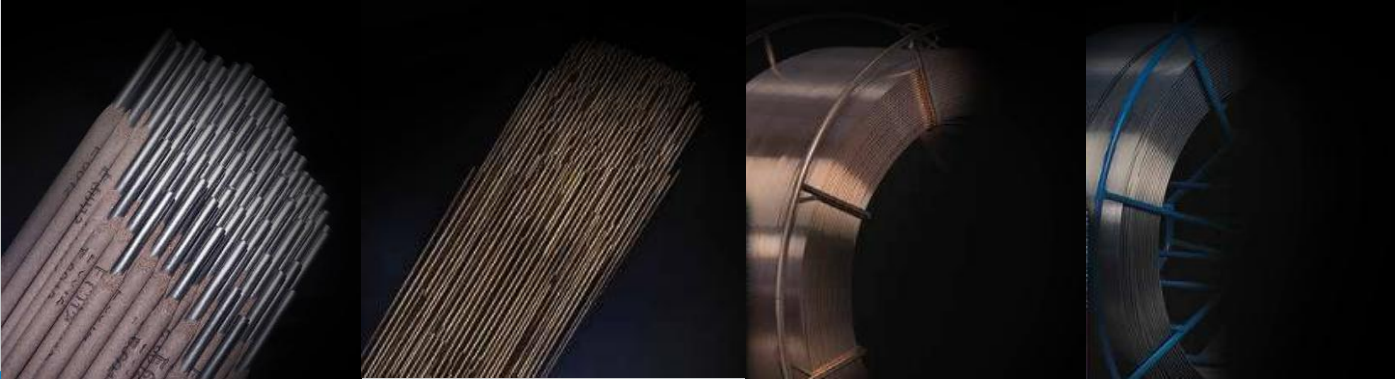

Special / General Welding Electrode & Filler

Repair and maintenance

- Cast iron
- Dissimilar welding
- Copper alloy consumables
- Hardfacing
- Special mild steel

- Full range of covered electrodes (MMA)
- Product development in accordance to customer's requests
- Quick response
- Flexibility
- Technical advice

COMPLETE WELDING SERVICE

STELLITE

STELLITE ALLOYS



Port Industry



Mining Industry

Improvement

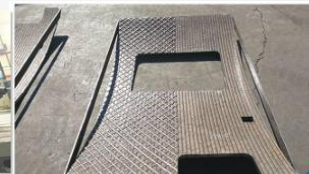

Power Industry



HARDFACING CONSUMABLES



Cement Industry





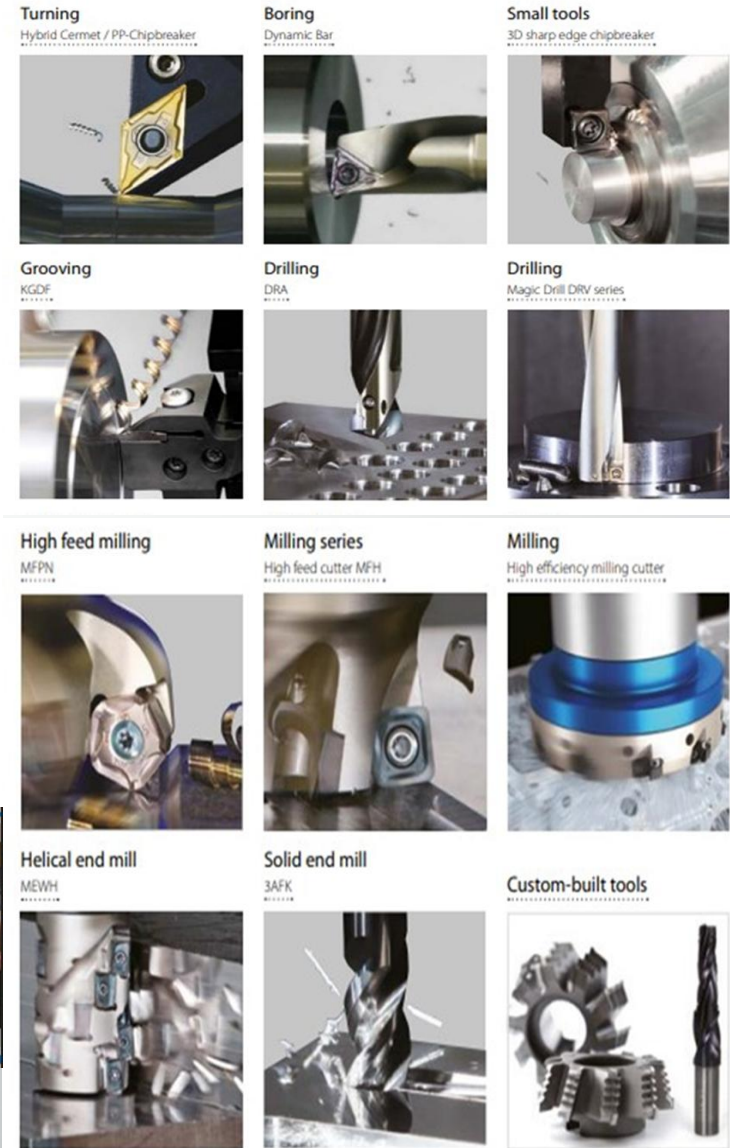
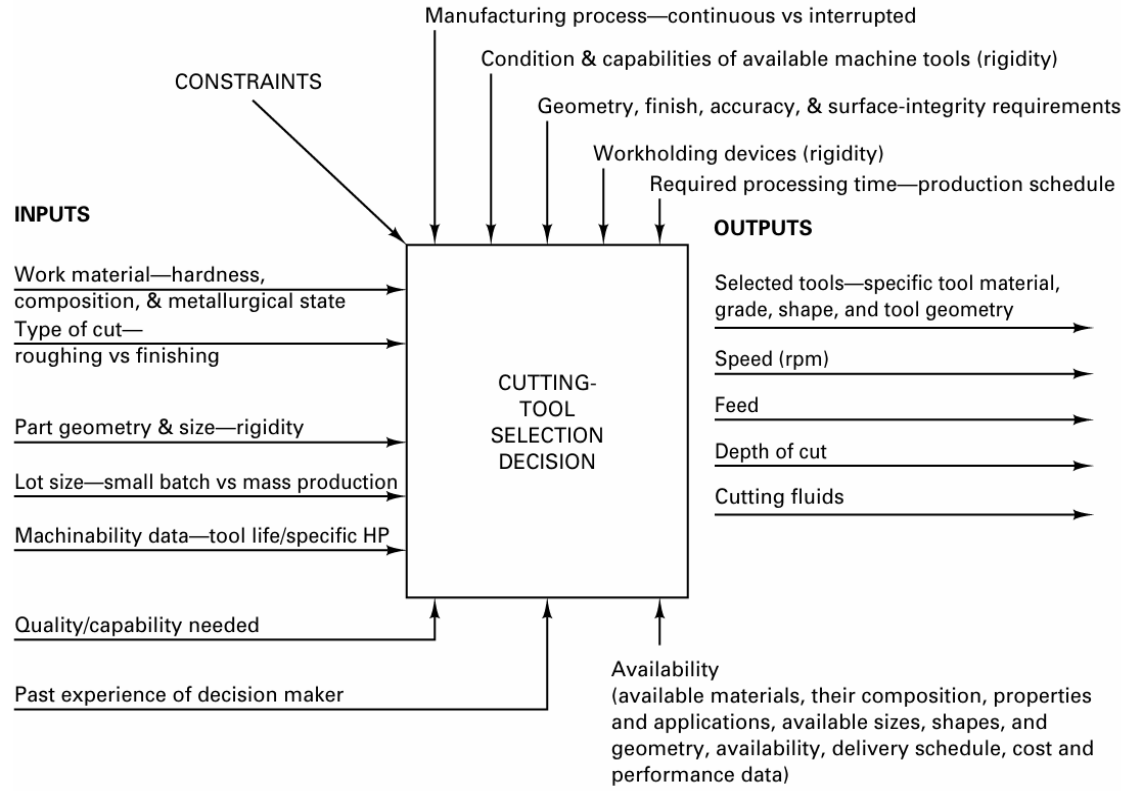





Special / General Holder & Insert With Accesories









Special Product Part

Advanced Metals

 Turbine Cases Rolls	 Tool Steel	Specialty Steel	 CVT Belt Materials	 Clad Materials	 Lead Frame Materials
Rolls for Steel Mills		Automotive Casting	 Cast Iron	 Heat-resistant cast components [HERCUNITE™]	
Piping Components	 Pipe Fittings	 Polyethylene gas piping systems			

Advanced Components and Materials

 Neodymium Magnets [NEOMAX®]	Magnetic Materials	 Ferrite Magnets [NMF™]
 Amorphous Alloys [Metglas®]	Power Electronics Materials	 SiN Substrate
 Rolling Stock Cables	Electric Wire & Cable	
 Industrial Robot Cable	Automotive Components	 Harness for Electric Parking Brakes



Machining

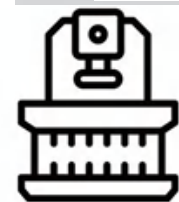

Forging



Centrifugal Casting

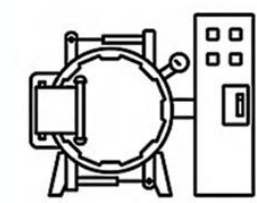

Vacuum Casting



Cladding & Finishing

Product Support Welding Machine



ST2-400/500/630A
Series MMA/SMAW
Welding Machines



TIG DC / ACDC
TIG Welders
315/400/500A



Artsen Plus D/P/Q Series
Intelligent Platform MIG/MAG
Welders **350/400/500A**



SA630/SA1000/SA1250
Series Submerged Arc Welding
Machines (SAW)

MEGMEET WELDING TECHNOLOGY

Robotic and Automatic Welding Power Sources

Seamlessly Integrated with Robotic Arc

Welding System like

FANUC, ABB, KUKA, YASKAWA



**Lux Series 4-in-1 Laser
Welding Machine**
(1.5KW/2KW/3KW)



Product Support Welding Torch

P-80(YT-10PD/YT10-PE)Air Cooled Plasma Cutting Torch

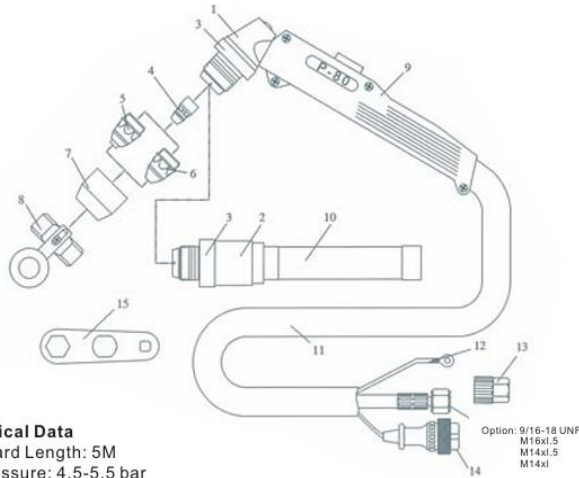

Technical Data
 Standard Length: 5M
 Air Pressure: 4.5-5.5 bar
 Duty Cycle 60%: 100A
 Duty Cycle 100%: 63A

Option: 9/16-18 UNF
 M16x1.5
 M14x1.5
 M14x1

WP-17 Series Air Cooled TIG Torch

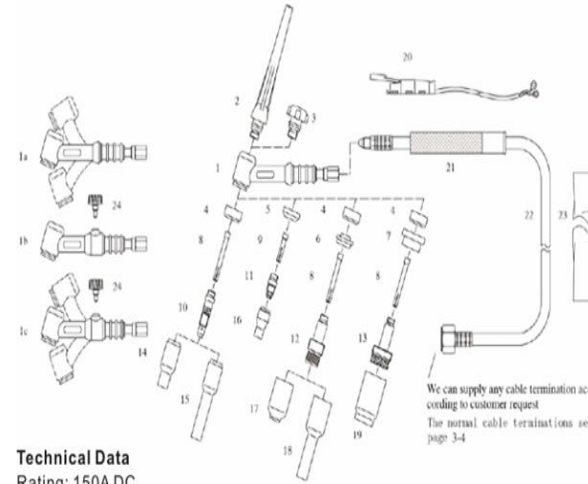

Technical Data
 Rating: 150ADC
 120AAC
 Duty Cycle: 60%
 Electrodes: 0.5~2.4mm

We can supply any cable termination according to customer request
 The normal cable terminations see page 3-4

MIG/MAG Welding Torch MB24KD

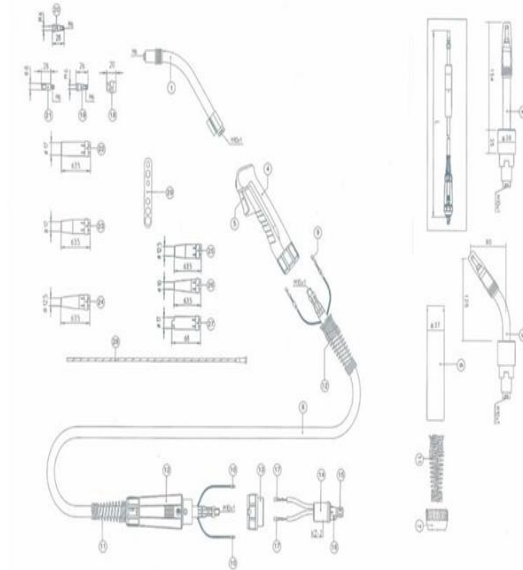

SR 9/SR 9V (FX)	SR 17/SR 17V (FX)	SR 18/SR 18V (FX)	SR 26/SR 26V (FX)
80 A	100 A	225 A	170 A
110 A	140 A	320 A	240 A
60 %	60 %	100 %	35 %
0.5-1.6 mm	0.5-2.4 mm	0.5-4.0 mm	0.5-4.0 mm
Air	Air	Water	Air

MB 15 AK	MB 24 KD	MB 25 AK	MB 36 KD	MB 40 KD	MB 501 D
180 A	250 A	230 A	330 A	300 A	550 A
150 A	220 A	200 A	300 A	270 A	500 A
60 %	35 %	35 %	60 %	60 %	100 %
0.6-1.0 mm	0.8-1.2 mm	0.8-1.2 mm	0.8-1.6 mm	0.8-1.2 mm	1.0-1.6 mm
Gas	Gas	Gas	Gas	Gas	Liquid
Euro	Euro	Euro	Euro	Euro	Euro

Plasma Torch With Accesories , Tig Torch With Accesories & Mig Torch With Accesories



Product Support Welding Accesories And Part

4

Interpass Cable

Cable Control 50 meter with Socket



6 Pins

Cable Welding 50 meter with Scun and Plug male female



95 mm

Hose gas 50 meter With Coupler



Cable Sleeves 50 meter



 Gas Nozzles	 Contact Tips	 Tip Holder
 Gas Diffusers	 Wire Conduits & Liners	 Wire Cap + Liners
 Carbon Gouging	 Gouging Torch	 Welding Helmet
 Electrode Oven 5 & 10 kg	 Hypertherm Plasma Cutting	 Lincoln Welding Consumables
 Rotary Flux Drying Oven	 Flame Cutting Torch	 Flame Cutting Tip

 Collets	 Gas Lenses	 Collet Bodies
 Ceramic Gas Nozzles	 Tungsten Electrodes	 Back Caps
 Gas Cutting Machine	 Gas Pipe Cutting Machine	 Gas Regulator
 Machine Panel Socket	 Cable Plug & Socket	 Electrode Holder
 Spot Cap Tip	 Plasma Cutting Consumables	 Backing Ceramic

SAFETY Equipment



Head Protection
Melindungi kepala dari benda jatuh ataupun benturan benda keras.



Face & Eye Protection
Melindungi mata dari debu, serpihan logam, cairan asam, gas, dan percikan api.



Hearing Protection
Melindungi telinga dari alat atau mesin yang bersuara keras.



Respiratory Protection
Melindungi pernapasan dari partikel debu dan gas beracun.



Hand Protection
Melindungi tangan dari benda tajam, benturan keras, bahan kimia dan biologis, bara api dan aliran listrik.



Protective Apparels
Baju safety memberikan perlindungan, kenyamanan dan kinerja secara optimal.



Foot Protection
Melindungi kaki dari benda jatuh, benda tajam, permukaan basah atau licin, bara api dan aliran listrik.



Fall Protection
Sebagai perlindungan saat bekerja di ketinggian dari cedera atau kematian.

Power Equipment / loading tools



pressure hydraulic tools



Electric chain hoist

Block chains

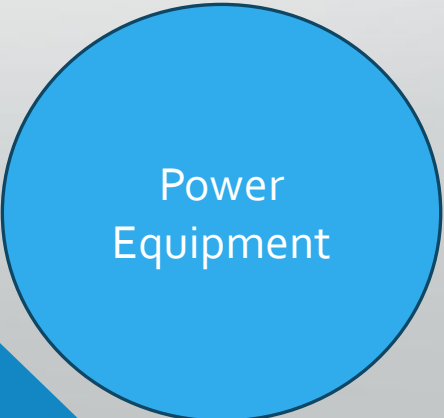

Power Equipment



Hand pallet truck

PA Mini electric hoist

Aluminum alloy winch

Pallet truck with scale

New type electric winch

With clutch electric winch

Mini Portable Crane

Aluminum shell electric winch

Electric winch

Chain block

Lever block

CD1 Electric wire rope hoist

Milwaukee
Nothing but **HEAVY DUTY.**

M12 FUEL

M18 FUEL

**MX
FUEL**

FORCELOGIC™

**PERFORMANCE DRIVEN
TRADE FOCUSED
SYSTEM WIDE**

Category

MX FUEL Tools

Cordless

Battery & Charger

MX Fuel Battery & Charger

Accessories & Hand Tools

Power
tools



EOC Series Lineup

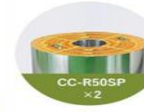

EOC-R3A	EOC-R10A	EOC-R25A	EOC-R50A	EOC-R100A
200 Watt	200 Watt	300 Watt	500 Watt	1,000 Watt
255 L x 360 W x 530 H (mm)	530 L x 310 W x 700 H (mm)	535 L x 350 W x 935 H (mm)	570 L x 530 W x 1,065 H (mm)	920 L x 550 W x 1,075 H (mm)
19 Kg	41 Kg	65 Kg	80 Kg	110 Kg
400 L	2500 L	6200 L	12000 L	24000 L



Metode instalasi dasar EOC

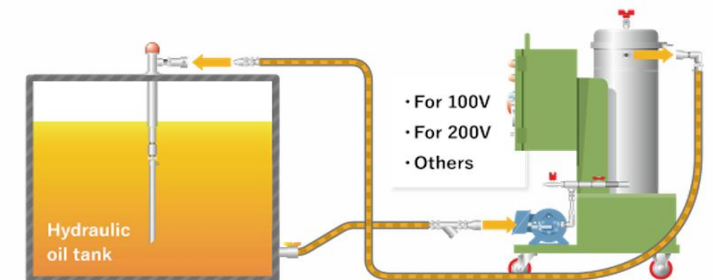

Electrostatic Oil Cleaner Sytem

Product Support System Overview II

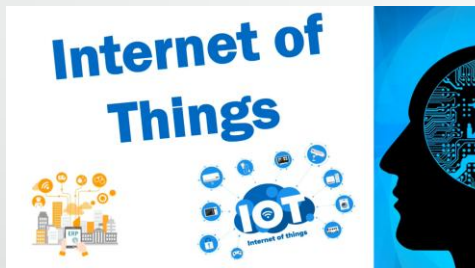
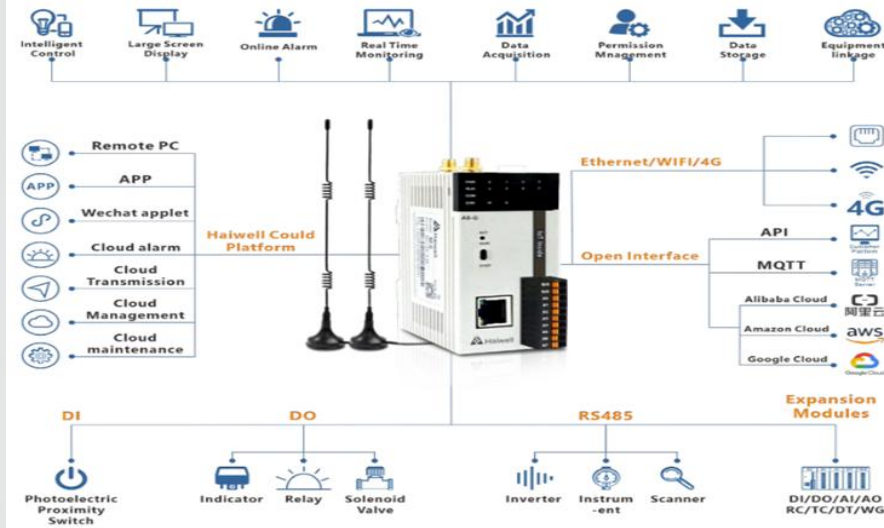

VALUE

- Actively partnering with customers in sustainable product engineering solutions by prioritising sales, service and support. In order to increase productivity, reduce costs and minimise risk.
- Our business is to understand the business our customers run by providing quality product solutions.

LUBRICATION
EXPLAINED
PRO

IOT System & Auto Lubrication System



PT. DUTA SOLUSINDO
TEKNIKATAMA
Industrial Product Supply

Product Support System Overview III

Megmeet SMARC welding system is mainly used for digital management of welding production. The system collects welding production data of welding equipment & welders through IOT devices, realizes real-time monitoring, storage, and statistical analysis.

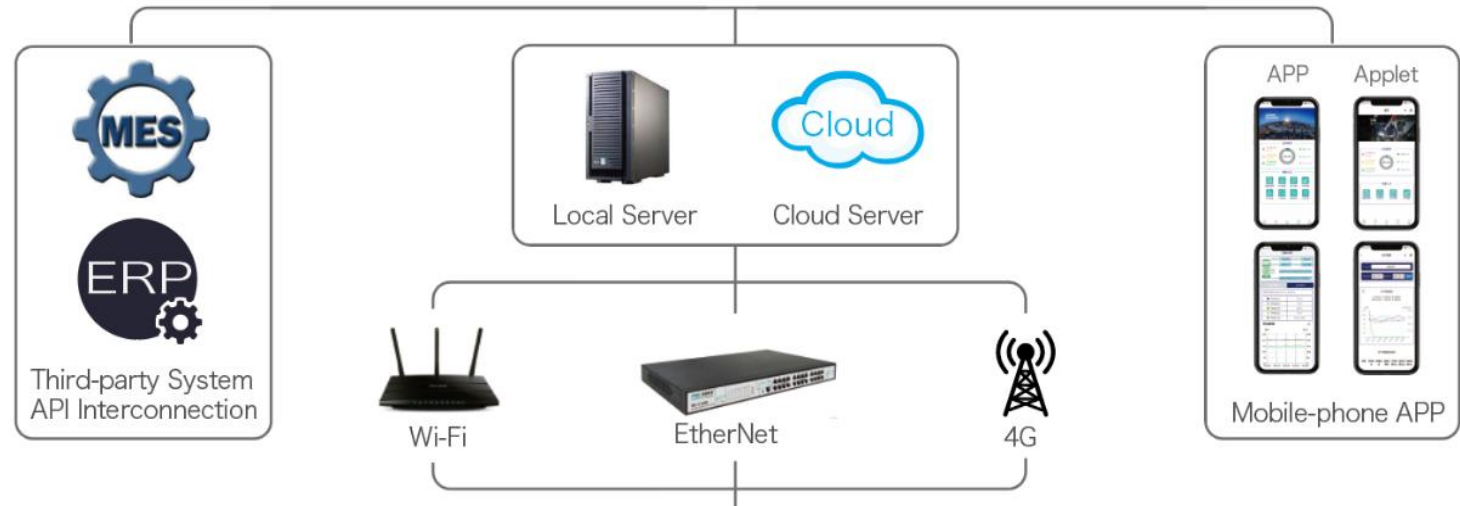

Service support Solution

Maintenance is the most important part of CNC lifecycle management.

Types of CNC Machine Maintenance

1. Preventive Maintenance

Scheduled inspections to identify early wear and prevent failures.

2. Predictive Maintenance

Monitoring spindle load, vibration, and temperature to forecast breakdowns.

3. Corrective Maintenance

Immediate repair when a machine stops functioning.

Regular Maintenance Services for CNC Machine can improve machine lifespan by 30–40% and reduce breakdowns significantly.



Every minute of downtime affects production. Professional **CNC Machine Repair Services** include:

- ✓ Electrical & mechanical troubleshooting
- ✓ Servo, spindle, and axis repairs
- ✓ Software/NC program debugging
- ✓ Replacement of faulty components
- ✓ On-site emergency service

Timely CNC Machine Repair and Maintenance prevents extended production loss and protects machine accuracy.



